

- THIS RECEPTACLE WILL MATE WITH ANY PLUG CONNECTOR WITH THE SAME INSERT ARRANGEMENT AS DEFINED BY MS14004-1.
 - MAXIMUM WIRE INSULATION USED WITH THIS RCPT. IS .054 [1.37] DIA.
 - Be-Cu RETENTION CLIPS ARE INCLUDED IN INSERTS.
- △4 INSPECTION REQUIREMENTS PER R4383.
 - △5 CONNECTOR SUPPLIED WITH 115 CONTACTS, AMP PART NUMBER 206071-1. INSPECTION REQUIREMENTS PER R4383 WITHOUT TESTS FOR HIGH ALTITUDE DIELECTRIC WITHSTANDING VOLTAGE AS CALLED FOR IN TABLE II SCREENING AND TESTING.
 - △6 UL/CSA DESIGNATION STAMPED IN THIS AREA, OPTIONAL
 - △7 SPECIAL TESTING PER GE DOCUMENT 20025720. CONNECTOR SUPPLIED WITH 114 CONTACTS, AMP P/N 206071-1.
 - △8 RESTRICTED TO CAE ELECTRONICS ONLY.
 - △9 THESE CONNECTORS ARE QUALIFIED TO GODDARD SPACE FLIGHT CENTER SPECIFICATION S-311-P-4.

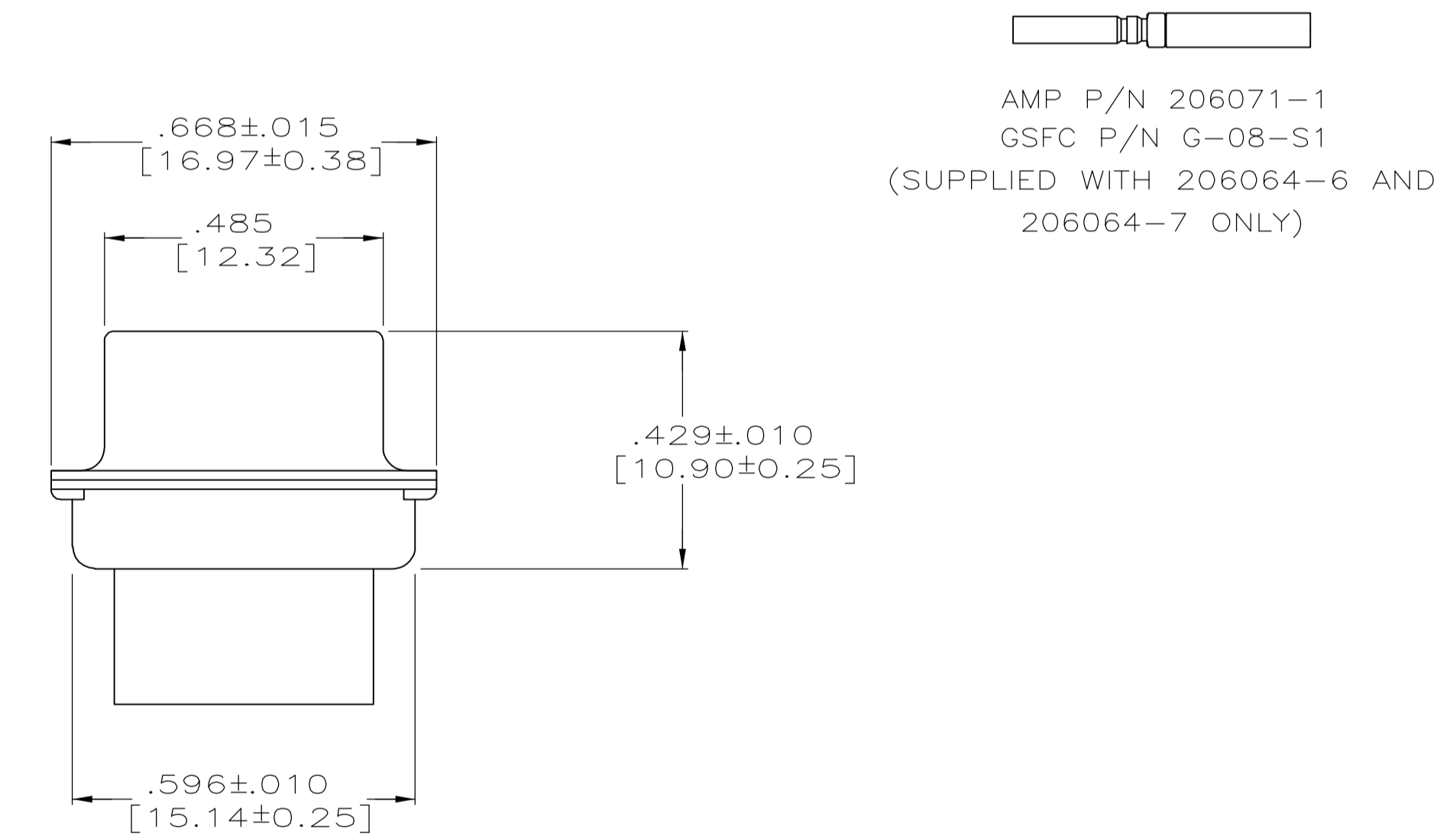

△8	.120 [3.05]	570566-6	206065-9	206065-9
△9	.120 [3.05]	311P407-6S-B-12	206065-4	206065-8
△7	.120 [3.05]	20025720P1104S	206065-7	206065-7
△5	.120 [3.05]	R4383P104S	206065-6	206065-6
△4	.120 [3.05]	R4383P104S-2	206065-5	206065-5
△9	.120 [3.05]	311P407-6S-B-12	206065-4	206065-4
---	.154 [3.91]	---	206065-3	206065-3
△9	.154 [3.91]	311P407-6S-B-15	206065-2	206065-2
---	.120 [3.05]	R9259P104S	206065-1	206065-1
REMARKS	DIA A	CUSTOMER P/N ON CONNECTOR	AMP P/N ON CONNECTOR	AMP P/N

THIS DRAWING IS A CONTROLLED DOCUMENT.

DIMENSIONS: INCHES	TOLERANCES UNLESS OTHERWISE SPECIFIED:	DWN: S. GLATFELTER 11-10-88	Tyco Electronics Corporation Harrisburg, PA 17105-3608
0 PLC ± - 1 PLC ± - 2 PLC ± - 3 PLC ± .005 [0.13] 4 PLC ± - ANGLES ± 0.30°	FINISH: SEE CALLOUTS	DSK: E. A. McDOUGLE 11-10-88 APVD: E. McDOUGLE 11-10-88 PRODUCT SPEC: --- APPLICATION SPEC: --- WEIGHT: ---	
MATERIAL: SEE CALLOUTS	FINISH: SEE CALLOUTS	NAME: AMPLIMITE NONMAGNETIC RECEPTACLE ASSEMBLY, SERIES 90, SHELL SIZE 6, 104 POSITION SIZE: A1 CAGE CODE: 00779 DRAWING NO: 206065 RESTRICTED TO: ---	CUSTOMER DRAWING SCALE: 4:1 SHEET: 1 OF 1 REV: R